

*Specification Grade Strips*

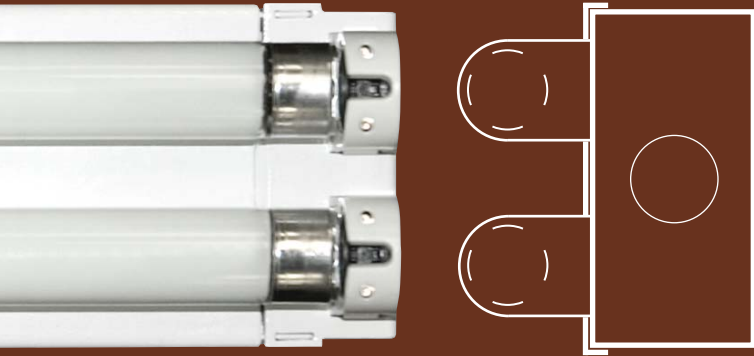

*Retail... Commercial... Institutional... Hospitality... Residential... Industrial*



# Versatile

*Strips are the most versatile luminaires in the lighting industry. Applications are driven by one's creativity, ranging from retail to industrial projects. The elementary form-follows-function design makes this product an ideal lighting instrument to incorporate into architectural features such as coves, slots, millwork and decorative elements.*



## CONTENTS

Product Features	4-6
Photometry	7
Product Matrix	8-9
Specifications	10-11
Applications	14-15

# Product Features

- 1 Die formed, 20 gauge cold rolled steel housing and 16 gauge cold rolled steel end caps.
- 2 High reflectance white electrostatically applied powder coat paint after fabrication.



2 5 7

6



1 3

8

**3** Housing designed for specification electronic ballast and battery packs.

**4** 7/8" End knock-outs for easy wiring. Quick through wiring is optional.

**5** Cover attaches with one screw for installation ease.

**6** Rotary lamp holder for positive lamp retention, IEC rated.

**7** UL / cUL listed. Damp location is optional.

**8** Mounting feet for stability.

**9** Multiple standard reflectors.  
Consult factory for custom reflectors.

**T5**

**T5HO**

**T8**

**Integral Ballast**  
**Remote Ballast**

**Staggered**  
**Telescoping**

**Customs**  
**Colors Available**

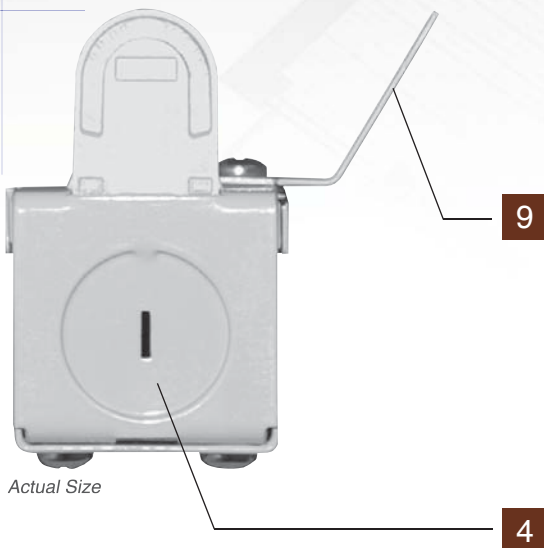

# Product Features

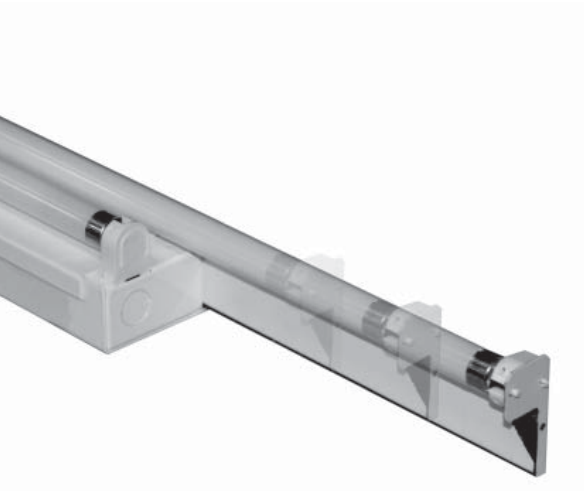

## Telescoping (SAL series)

Our telescoping 2-light strip is designed to fill-in illumination at the end of a run or used individually where adjustment is needed for a particular application. The luminaire can extend up to 12" and retract 6" or 3" when mounted individually.

### Continuous Row

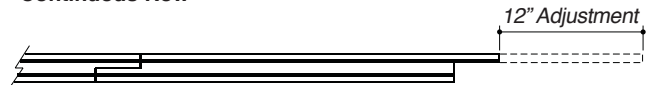

### Individual Luminaire



## Snap-on Lens (FRS option)

The optional snap-on frosted lens is available for one-light luminaires. The extruded frosted lens is ideal for projects that require added lamp protection, or to soften lamp brightness. The open end design allows air flow around the lamp. A lens will be supplied per lamp. For example, a nominal 8' luminaire will have two nominal 4' lenses.



## Emergency Battery Pack (EM option)

Nulite designed the new specification grade strip housing to accommodate reduced or low profile emergency battery packs. Each luminaire with the EM option is provided with an indicator light and test switch located at the end of the housing. For side-mount luminaires, the indicator light and test switch are located in the ballast cover. Emergency battery pack is not available in nominal 2' units, and consult factory for nominal 3' units.

Photometric data of our standard reflectors.

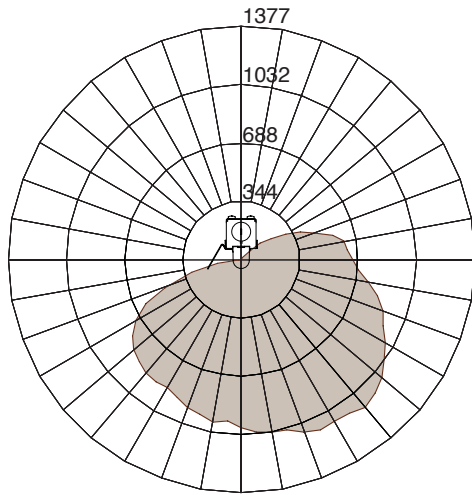

**Cat. # SA-154T5HO...ASY\***

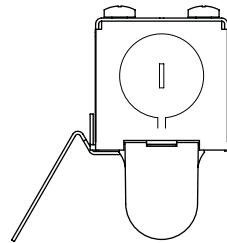

**Cat. # SA-154T5HO...SYM\***

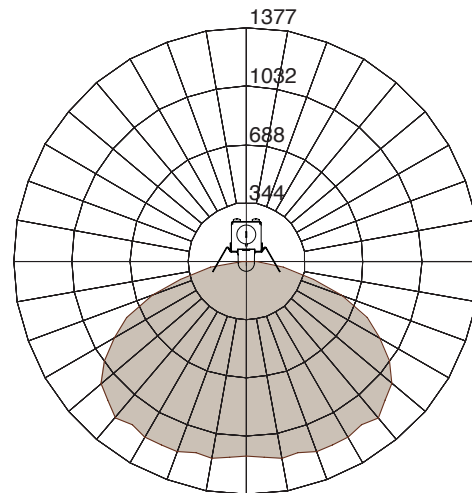
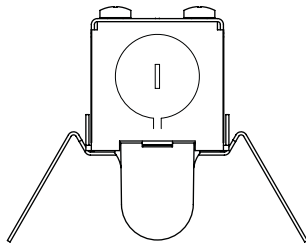

**Cat. # SA-154T5HO...RASY\***

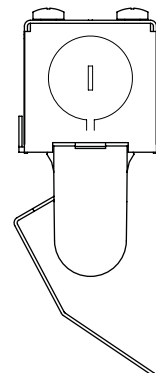
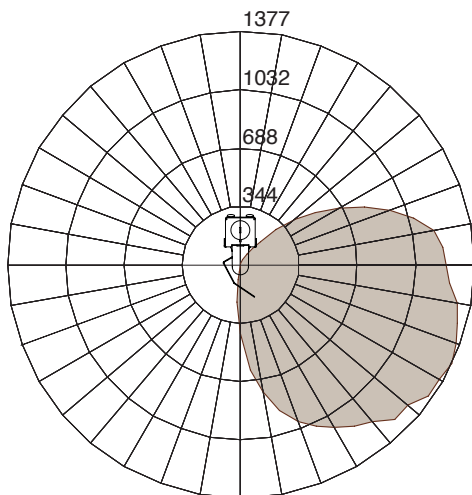

\* Initial lamp lumens - 5,000. Housing and solid reflector are finished with high reflectance white baked powder coat paint after fabrication.

# Product Matrix

T5 Products

Nulite is a leader in specification grade fluorescent strips. We offer luminaires in T5, T5HO or T8 lamping, integral or remote ballast configurations, with multiple standard reflectors and finishes. If you're looking for a modification, give us a call because customs are our niche.

## Integral

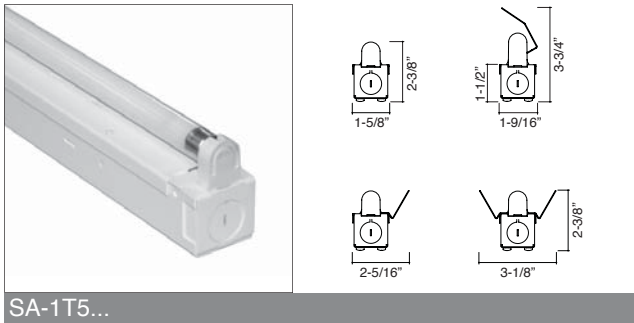

## Integral Staggered

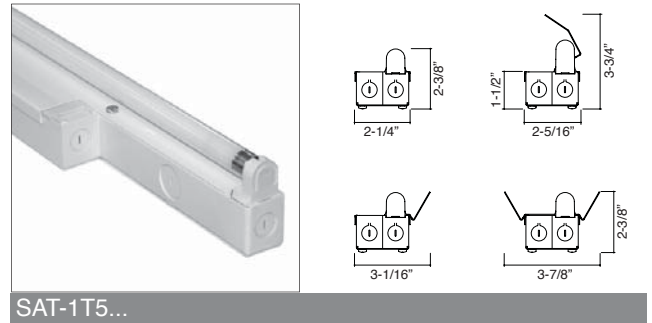

## Integral

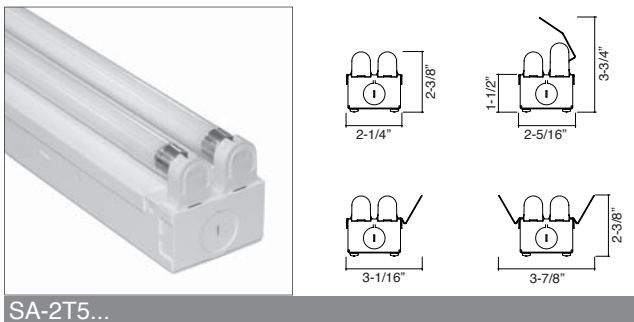

## Integral Staggered

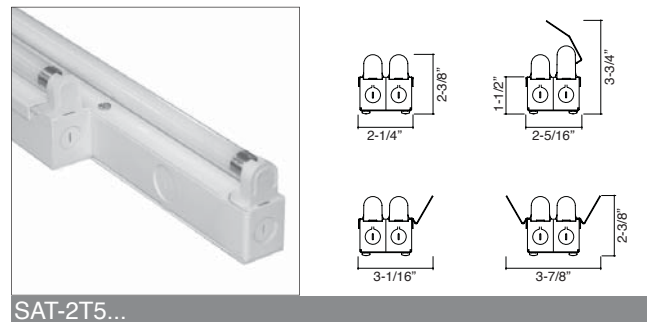

## Integral Side Mount

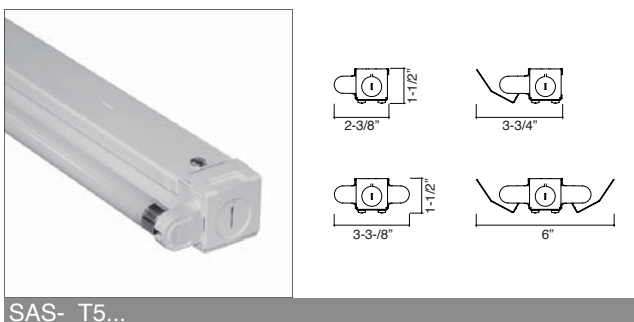

## Integral Telescoping

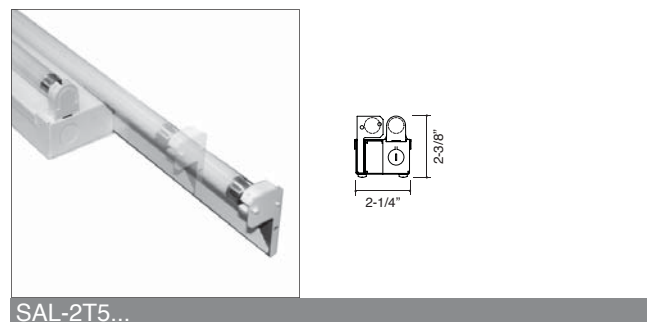

## Integral Right Angle

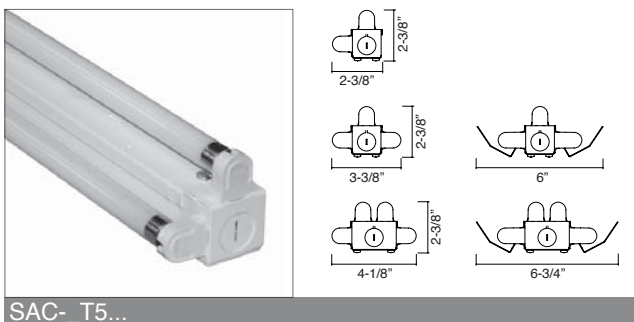

## Remote

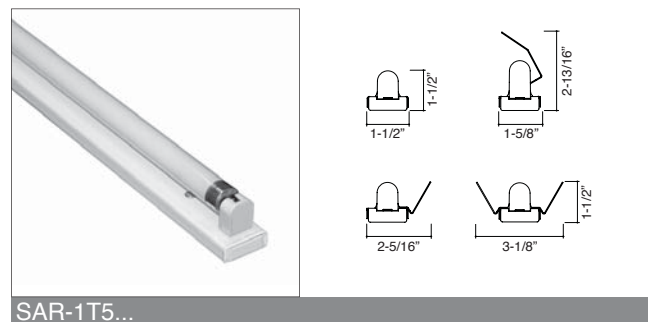



T8 Products

Integral

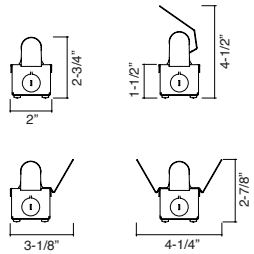

SA-1T8...

Integral Staggered

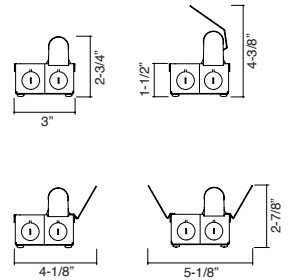

SAT-1T8...

Integral

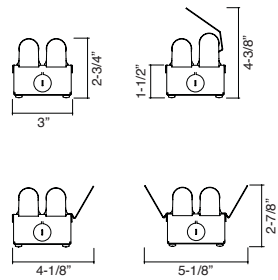

SA-2T8...

Integral Staggered

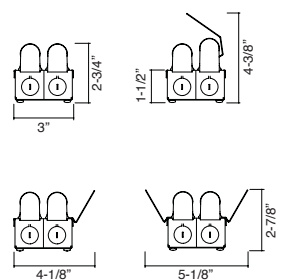

SAT-2T8...

Integral Side Mount

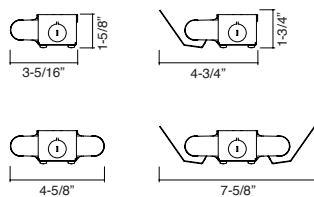

SAS-T8...

Integral Telescoping

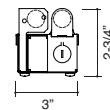

SAL-2T8...

Integral Right Angle

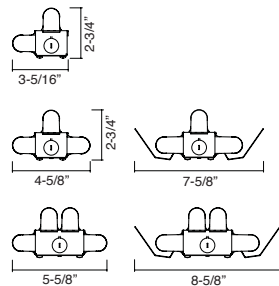

SAC-T8...

Remote

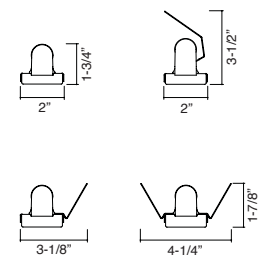

SAR-1T8...



**Construction:** Die formed 20 gauge cold rolled steel housing and 16 gauge cold rolled steel end caps. The housing is finished in high reflectance white baked polyester powder coat paint after fabrication. Optional aluminum or stainless steel housing.

**Reflector / Housing:** Reflector / ballast cover is finished with high reflectance white baked polyester powder coat paint after fabrication. Consult factory for custom reflectors. Standard electronic, Class P, ballast.

**Lamping:** T5 or T5HO. Luminaire can be ordered with lamps, consult factory.

**Mounting:** Surface

**Labels:** UL / cUL listed. Damp location is optional.

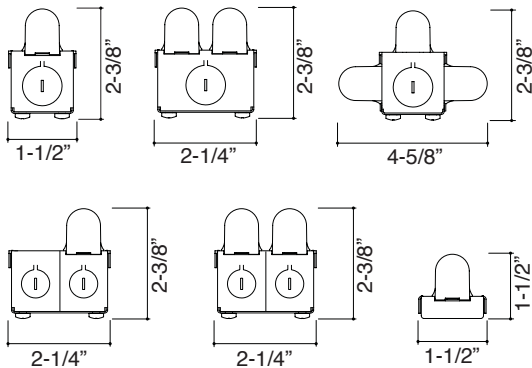

Length Chart

Wattage	SA, SAS, SAC	SAR	SAT-1	SAT-2
14T5, 24T5HO	22-1/2"	23-7/8"	22-1/2"	28-3/8"
21T5, 39T5HO	34-3/8"	35-5/8"	34-3/8"	40-3/16"
28T5, 54T5HO	46-1/8"	47-1/2"	46-1/8"	52-3/16"
21T5-6, 39T5HO-6	68-3/4"	N/A	62-3/4"	74-3/4"
28T5-8, 54T5HO-8	92-3/16"	N/A	86-1/4"	98-3/16"

Project:	Type:
Date:	
Catalog #:	

**Ordering Information**

Sample: SA-154T5HO-UNV-PSN-DL-ASY

Series	SA = Strip Architectural Integral SAR = Strip Architectural Remote SAT = Strip Architectural Staggered SAL <sup>1</sup> = Strip Architectural Telescoping SAS = Strip Architectural Side-mount SAC = Strip Architectural Right Angle
Lamp	1 2 3 <sup>2</sup> 4 <sup>2</sup>
Wattage	14T5            24T5HO 21T5            39T5HO 28T5            54T5HO 21T5-6        39T5HO-6 28T5-8        54T5HO-8
Voltage	UNV = Universal (120 to 277V) 120 277 347 <sup>3</sup> 480 <sup>3</sup>
Ballast	PSN = Program Start / Normal B.F. HEPSN <sup>3</sup> = High Efficiency Program Start / Normal B.F. DIM <sup>3</sup> = Dimming SD <sup>3</sup> = Step Dimming
Options	EM <sup>4</sup> = Emergency Battery Pack AL = Aluminum Housing SS = Stainless Steel Housing DL = Damp Location SYM = Symmetrical Reflector ASY = Asymmetrical Reflector RASY = Reverse Asymmetrical Reflector WG <sup>1</sup> = Wireguard FRS <sup>5</sup> = Frosted Snap-on Lens QW = Quick Through Wiring GLR = Fusing

Notes:

1. Consult factory for reflector options.
2. 3 or 4 lamp are only available for the SAC series.
3. Consult factory.
4. Emergency is not available for 2' unit; consult factory for 3' unit. Specific voltage must be ordered for this option.
5. 1-Light cross-section only.

Project:	Type:
Date:	
Catalog #:	

**Ordering Information**

Sample: SA-232T8-UNV-ISN-DL-SYM

Series	SA = Strip Architectural Integral SAR = Strip Architectural Remote SAT = Strip Architectural Staggered SAL <sup>1</sup> = Strip Architectural Telescoping SAS = Strip Architectural Side-mount SAC = Strip Architectural Right Angle	
Lamp	1, 2, 3 <sup>2</sup> , 4 <sup>2</sup>	
Wattage	17T8, 25T8, 32T8, 25T8-6, 32T8-8	
Voltage	UNV = Universal (120 to 277V), 120, 277, 347 <sup>3</sup>	
Ballast	IS = Instant Start PS = Program Start HEIS = High Efficiency Instant Start HEPS = High Efficiency Program Start	N = Normal B.F. L = Low B.F. H = High B.F.
Options	DIM <sup>3</sup> = Dimming SD <sup>3</sup> = Step Dimming EM <sup>4</sup> = Emergency Battery Pack AL = Aluminum Housing SS = Stainless Steel Housing DL = Damp Location SYM = Symmetrical Reflector ASY = Asymmetrical Reflector RASY = Reverse Asymmetrical Reflector WG <sup>1</sup> = Wireguards FRS <sup>5</sup> = Frosted Snap-on Lens QW = Quick Through Wiring GLR = Fusing	



**Construction:** Die formed 20 gauge cold rolled steel housing and 16 gauge cold rolled steel end caps. The housing is finished in high reflectance white baked polyester powder coat paint after fabrication. Optional aluminum or stainless steel housing.

**Reflector / Housing:** Reflector / ballast cover is finished with high reflectance white baked polyester powder coat paint after fabrication. Consult factory for custom reflectors. Standard electronic, Class P, ballast.

**Lamping:** T8. Luminaire can be ordered with lamps, consult factory.

**Mounting:** Surface

**Labels:** UL / cUL listed. Damp location is optional.

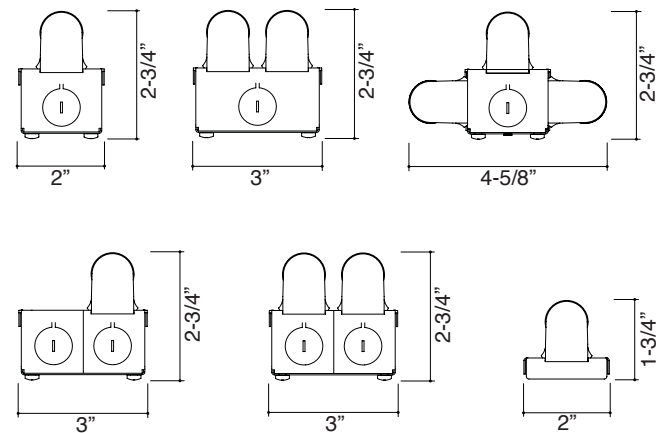

Length Chart

Wattage	SA, SAS, SAC	SAR	SAT-1	SAT-2
17T8	24"	25-3/8"	24"	27"
25T8	36"	37-3/8"	36"	39"
32T8	48"	49-3/8"	48"	51"
25T8-6	72"	N/A	69"	75"
32T8-8	96"	N/A	93"	99"

- Notes:
1. Consult factory for reflector options.
  2. 3 or 4 lamp are only available for the SAC series.
  3. Consult factory.
  4. Emergency is not available for 2' unit; consult factory for 3' unit. Specific voltage must be ordered for this option.
  5. 1-Light cross-section only.



# Integrate

*The integration of lighting into the architectural features gives a space a cohesive feeling, and creates visual interest in the environment. Cove lighting is an ideal way to add an indirect component for a layered illumination effect.*



# Applications

## Cove Design Recommendations

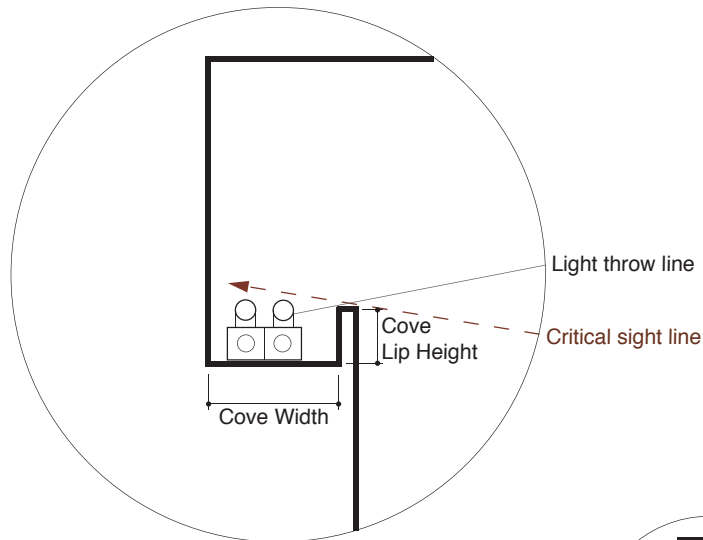

### NOTE:

Nulite recommends finishing the interior surfaces matte white for maximum performance. The interior surfaces will reflect light to minimize shadows and maximize light output. In addition, the illuminated surface should have a matte finish to reduce lamp reflections and socket shadows.

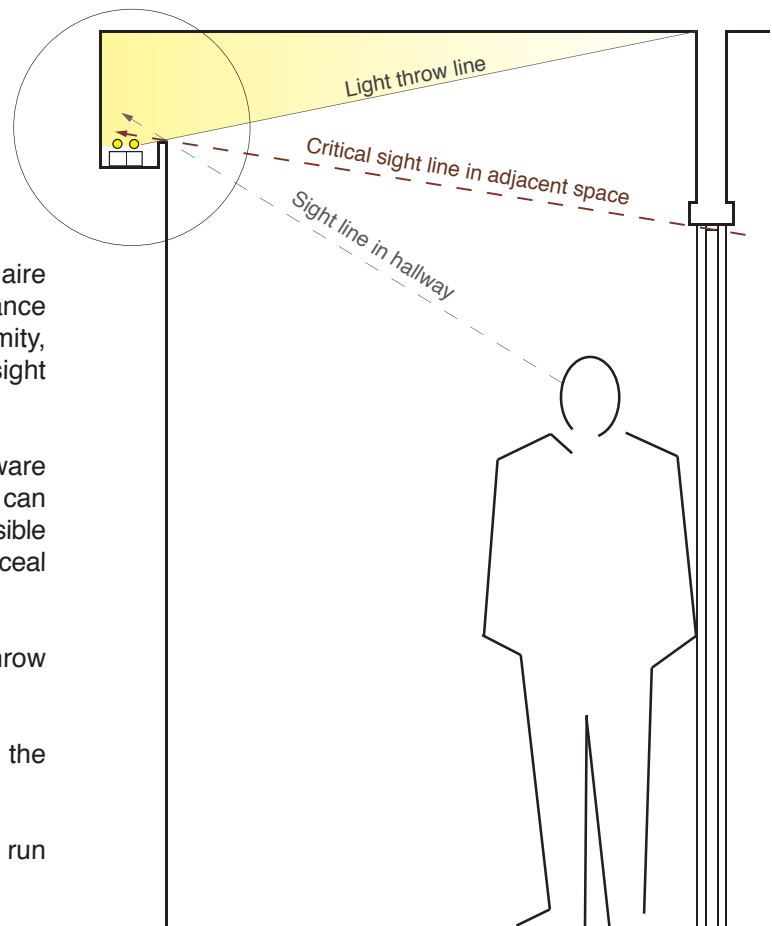

1. Determine the location of the cove and luminaire for the particular application. Increasing the distance from the illuminated surface improves the uniformity, efficiency and throw distance but can affect the sight line.
2. Determine the critical sight line in the space. Beware of stairs, escalators and balconies. These features can require greater than horizontal cutoff. The farthest visible point can be in adjacent locations. The goal is to conceal the lamp brightness from one's field of view.
3. The intersection of the critical sight line and throw line will determine the top of the cove lip.
4. Make sure there is adequate clearance around the luminaire for installation and maintenance.
5. Leave adequate space at the ends of the run (approximately 6") for installation.

## Typical Applications

Commercial projects can have a custom lighting appearance by incorporating strips into simple details. For instance, a field constructed valance provides an integrated appearance and soft ambient illumination.

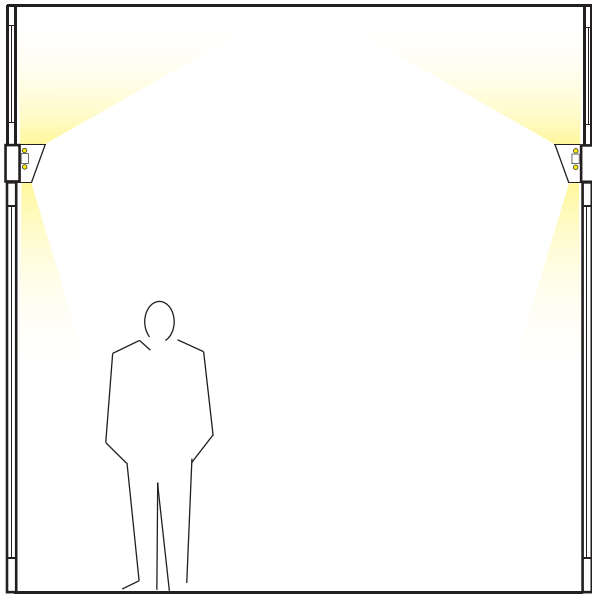

A recessed perimeter ceiling slot is an excellent way to increase the visual size of the space and highlight merchandise.

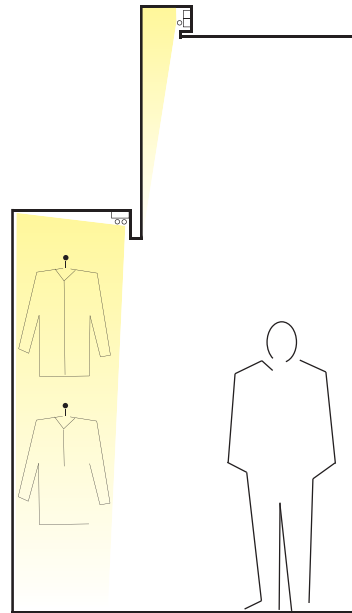

The integration of lighting into millwork can give a retail space a high-end appearance, and creates visual interest.

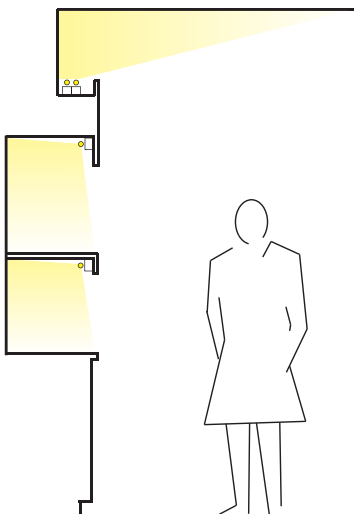

Industrial workspaces are ideal application for strips. The local task lighting improves visibility for assembly and can reduce overall lighting energy consumption.

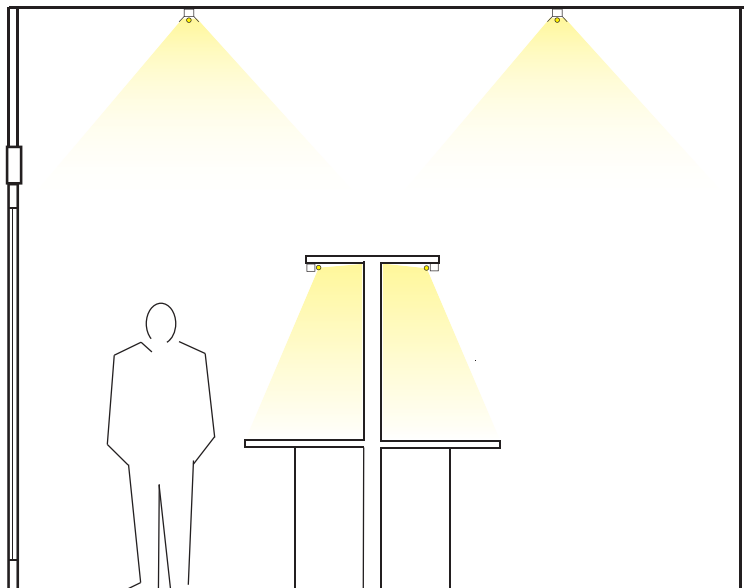

## *Specification Grade Strips*

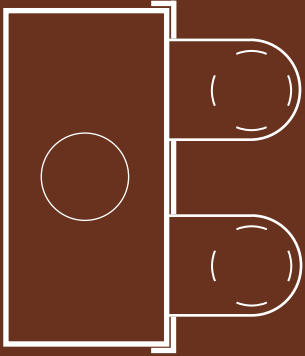

**NULITE™**

10770 East 51st Avenue

Denver, CO 80239

Phone 303-287-9646

Fax 303-287-0316

[www.nulite-lighting.com](http://www.nulite-lighting.com)